



**Hastelloy / Monel /
Stainless Steel**

FLOW METER LIMITED WARRANTY

Meters are warranted against defects in materials and workmanship to the original user for a period of thirteen (13) months from the date of factory shipment, provided the meter is installed, operated and maintained in accordance with King Instrument Company's instructions and recommendations.

This warranty does not apply if failure is caused or contributed to by any of the following: improper handling, improper storage, abuse, unsuitable application of the product, lack of reasonable and necessary maintenance, use exceeding suggested pressure and temperature maximums, improper packaging for return, or repairs made or attempted to be made by anyone other than King Instrument Company, Inc.

KING INSTRUMENT COMPANY, INC. MAKES NO WARRANTY AS TO THE FITNESS OF ITS PRODUCTS FOR SPECIFIC APPLICATIONS.

This warranty is valid for the original end-user only and does not apply to products that have been damaged or modified. This warranty is non-transferrable and is limited to replacement or repair. The liability of King Instrument Company arising out of its supply of the products, or their use, shall not in any case exceed the cost of correcting defects in the products as set forth above.

THIS WARRANTY IS A LIMITED WARRANTY AND SHALL BE IN LIEU OF ANY OTHER WARRANTIES, EXPRESSED OR IMPLIED, INCLUDING BUT NOT LIMITED TO ANY IMPLIED WARRANTY OR MERCHANTABILITY OR FITNESS FOR A PARTICULAR PURPOSE. THERE ARE NO OTHER WARRANTIES WHICH EXIST BEYOND THE DESCRIPTION OR FACE HEREOF.

IN NO EVENT SHALL KING INSTRUMENT COMPANY BE LIABLE FOR LOSS OF PROFITS, INDIRECT, CONSEQUENTIAL OR INCIDENTAL DAMAGES.

Products should be returned, prepaid, to King Instrument Company, Inc. with proof of purchase. Call factory for Return Merchandise Authorization (RMA) number and return instructions.

THIS IS IMPORTANT INFORMATION. READ IT CAREFULLY BEFORE BEGINNING WORK.

- 1) Inspect meter for damage that may have occurred during shipping. Report any damage to the container to the freight carrier immediately.
- 2) Make sure your pressure, temperature, fluid and other requirements are compatible with the meter (including o-rings.)
- 3) Select a suitable location for installation to prevent excess stress on the meter which may result from:
 - a) Misaligned pipe.
 - b) The weight of related plumbing.
 - c) "Water Hammer" which is most likely to occur when flow is suddenly stopped as with quick closing solenoid operated valves. (If necessary, a surge chamber should be installed. This will also be useful in pressure start-up situations.)
 - d) Thermal expansion of liquid in a stagnated or valve isolated system.
 - e) It is recommended to install valving which will allow the meter to be drained. Meter should be drained when not in use or prior to maintenance.
 - f) Instantaneous pressurization which will stress the meter and could result in tube failure.
- 4) Handle the meter carefully during installation.
 - a) Use an appropriate amount of teflon tape on external pipe threads before making connections. Do not use paste or stick type thread sealing products.
- 5) Install the meter vertically with the inlet port at the bottom.
- 6) Meters with stainless steel fittings will support several feet of pipe as long as significant vibration or stress resulting from misaligned pipe are not factors.
- 7) Meters used in gas service should have suitable valves plumbed in at the inlet and outlet of the meter. These valves should be no more than 1-1/2 pipe diameters from the meter ports. The valve at the outlet should be used to create back pressure as required to prevent float bounce. It should be set initially and then left alone. The inlet valve should be used for throttling purposes. Depending on the installation, valves may not be essential, but they are most useful in many installations. Remember: To get a correct reading of flow in gas service, it is necessary to know the pressure right at the outlet of the meter (before the valve).
- 8) Pressure and temperature maximums must never be exceeded.

NOTE: In closed thermal transfer or cooling systems, install the meter in the cool side of the line to minimize meter expansion and contraction and possible fluid leaks at the threaded connections.

Maximum Non-Shock Pressure and Temperature		
	Temp	Pressure
Liquid	200° F	200 (SS)
		130 psig (PVC)
Gas	250° F	150 psig (PVDF)
Ambient Temp. 33° F -125° F		

CAUTION

- 7430 Series meters have o-ring seals. Use with incompatible fluid may cause o-rings to swell which may cause glass tube to fail.
- Plastic fittings are not suitable for gas applications.
- Extra caution must be exercised when meters are used in high pressure gas cylinder applications. Pressure regulators should be installed at the cylinder and at the inlet of the meter.
- Serious property damage and great personal injury could occur as the result of a meter misused or used in an unsuitable application.

DO NOT USE AN INLET OR OUTLET VALVE AS A SHUT-OFF VALVE.

Valves are designed to be used to control flow only. Do not use an inlet or outlet valve as a way to shut-off a system. This can cause damage to the meter as well as the system it is installed in. In an outlet valve configuration, too much pressure can build up in the meter and cause a failure in the tube if used as a shut-off valve.

CLEANING

To minimize down time, 7430 Series metering tubes are designed to be removed without uninstalling flowmeter from piping system. Meter should be drained prior to maintenance.

Carefully remove the flowmeter from the piping system. Remove the front shield and the top frame plug. Insert a 5/32" hex key through the top hole of the frame and into the compression screw. Turn the hex key counter clockwise until the compression screw is raised enough to be able to remove the glass tube. Carefully remove the glass tube. Remove the compression screw by turning the hex key clockwise. Float and float stops may be removed by inserting a rod into one end of the glass tube and carefully pushing the components out the other end.

Valve Models: Remove valve from the bottom end fitting using a 7/16" open ended wrench. Disassembly of valve is not recommended. Outer valve o-ring should be replaced during meter maintenance and cleaning. Prior to reinstalling valve, apply blue Loctite R to valve threads and a silicone based lubricant onto o-rings.

Non-Valve Models: Remove valve orifice plug from bottom end fitting by inserting a 3/16" hex key through the back of the end fitting and into the plug. Turn clockwise to remove it.

All components are now fully accessible for cleaning. Components can be cleaned with a mild soap solution. This will be an effective cleaner of rust stains. A cotton swab may be helpful in cleaning the inside of the glass tube. Caution must be used so that materials of construction are not damaged by cleaning solutions. Hard water deposits can be removed with a 5% acetic acid solution (vinegar).

Before the meter is reassembled, inspect all parts for damage. O-rings should be replaced during meter maintenance and cleaning.

To reassemble, insert bottom float stop into glass tube and push it down with a rod. Insert the ball float and top float stop. Install the compression screw with the 5/32" hex key, turning counter clockwise. Install the gaskets, seat bushing, and tube adapters (1/8" float models only). Position glass tube in frame assembly and begin to turn the compression screw clockwise. Make sure that the tube is centered and that the reference line is facing forward. Tighten compression screw to 4 in. lbs. of torque. Re-install the frame orifice plug. Re-install valve assembly or valve orifice plug. Replace shield by snapping it into place.

REPAIR

7430 meters that require repair should be sent to the factory. Please call for a Return Merchandise Authorization (RMA) number and return instructions.

WARNING:

Pressure and temperature ratings are based on a study of the engineering data for particular materials used in construction and on the design of individual models. This information is supplemented by destructive test results. Meters with stainless enclosures must never be operated without shields securely in place. Meters exposed to difficult environments such as those created by certain chemicals, excessive vibration or other stress inducing factors could fail at or below the suggested maximums. Never operate meters above pressure and temperature maximums. It is strongly recommended that all meter installations utilize an appropriate pressure relief valve and/or rupture disc. The pressure settings and locations of these devices should be such that meters cannot be over pressurized. Meter failure could result in damage to equipment and serious personal injury. Always use suitable safety gear, including OSHA approved eye protection when working around meters in service. We are happy to pass along chemical compatibility information that has been published by the manufacturer's of raw materials used in our products; however, this information should not be construed as a recommendation made by King Instrument Company, Inc. for a specific application.

FLOAT TYPES AND ORIENTATIONS

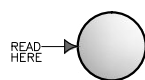

BL FLOAT

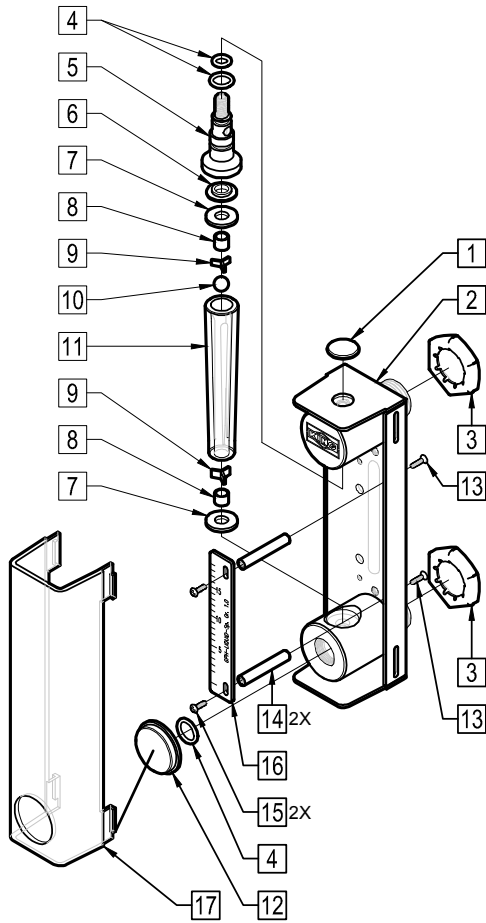

7430 SERIES ASSEMBLY NON-VALVE PARTS LIST:

- | | |
|----------------------|-----------------------------|
| 1. Top Frame Plug | 10. Float |
| 2. Frame Assembly | 11. Glass Meter Tube |
| 3. Retaining Nut | 12. End Fitting Plug |
| 4. O-Ring | 13. Scale Plate Mount Screw |
| 5. Compression Screw | 14. Scale Plate Mount |
| 6. Seat Bushing | 15. Scale Plate Screw |
| 7. Glass Tube Gasket | 16. Scale Plate |
| 8. Tube Adaptor | 17. Shield |
| 9. Float Stop | |

7430 SERIES ASSEMBLY INLET VALVE OUTLET VALVE SIMILAR PARTS LIST:

- | | |
|-----------------------------|-----------------------|
| 1. Top Frame Plug | 14. Scale Plate Screw |
| 2. Frame Assembly | 15. Scale Plate |
| 3. Retaining Nut | 16. Valve Assembly |
| 4. O-Ring | 17. Shield Spacer |
| 5. Compression Screw | 18. Shield |
| 6. Seat Bushing | |
| 7. Glass Tube Gasket | |
| 8. Tube Adaptor | |
| 9. Float Stop | |
| 10. Float | |
| 11. Glass Meter Tube | |
| 12. Scale Plate Mount Screw | |
| 13. Scale Plate Mount | |

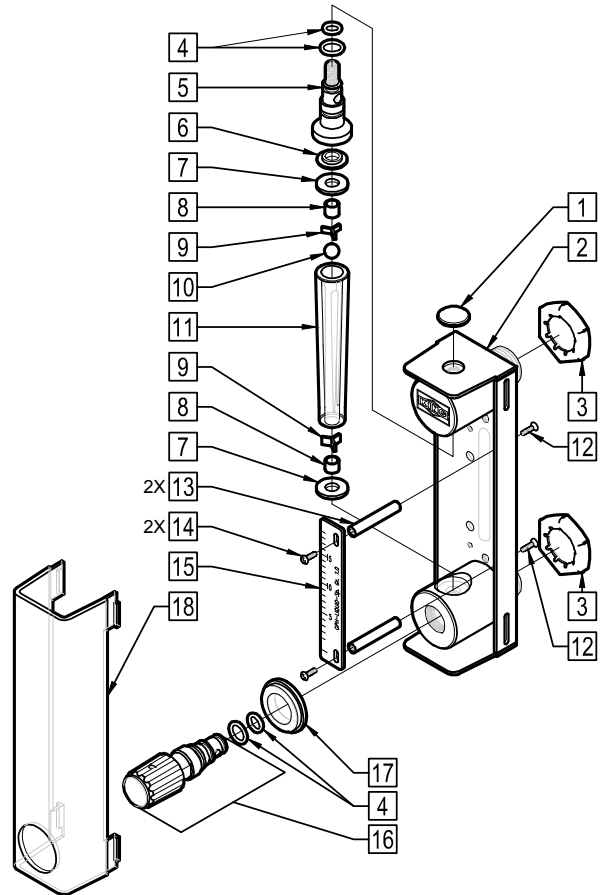

7430 SERIES INDUCTIVE RING SENSOR

INDUCTIVE RING SENSOR:

All 7430 Series flowmeters may be fitted with one inductive ring sensor.

The inductive ring sensor is mounted on the glass meter tube using springs to put tension between the frame and glass meter tube.

The sensor can be either proximity or latching type and can only be used with 316SS or Carbonyl floats. The inductive ring sensor produces an electromagnetic field that senses the metal float within sensing zone.

Inductive ring sensors are 2-wire, DC, low current devices and are designed to be used with a remote intrinsic safety barrier / switch isolator.

SWITCH ISOLATOR:

Inductive ring sensors are designed to be connected to a switch isolator for intrinsically safe applications. The purpose of the switch isolator is to supply electrical signals between safe and hazardous areas in either direction while limiting the amount of energy that can be transferred even under fault conditions. Switch isolators are available with 220VAC, 110VAC or 24VDC supply voltage requirements, contain single pole double throw (SPDT) relays, and are DIN rail mountable. See switch isolator specifications for electrical connections and further details.

INDUCTIVE RING SENSOR-ELECTRICAL SPECIFICATIONS

TYPE:	INDUCTIVE PROXIMITY OR LATCHING	
SUPPLY VOLTAGE:	5-25V DC (Switch Isolator)	
OUTPUT:	NAMUR	
OUTPUT LOAD CURRENT:	≤ 1mA-Float Present ≥ 3mA (15mA Max.)-Float Absent	
SWITCHING FREQUENCY:	2KHZ	
HOUSING RATING:	IP67	
OPERATING TEMPERATURE:	-13°F to 104°F	1/8" Latching
	-13°F to 158°F	1/8" Proximity
		1/4" Latching
		1/4" Proximity
WIRING:	PVC covered, 2 Conductor, 26 AWG, 6.5 Ft. Long. Brown (+) / Blue (-)	
PEPPERL+FUCHS	UL:	General Purpose
SENSOR APPROVALS	FM:	Intrinsically Safe
	CSA:	Intrinsically Safe
	CENELEC:	Intrinsically Safe

7430 SERIES ASSEMBLY WITH INDUCTIVE RING SENSOR PARTS LIST:

1. Top Frame Plug
2. Frame Assembly
3. Glass Meter Tube Assembly
4. Inductive Ring Sensor
5. Sensor Tension Spring
6. Alarm Junction Box
7. Alarm Junction Box Screw
8. Strain Connector
9. Shield

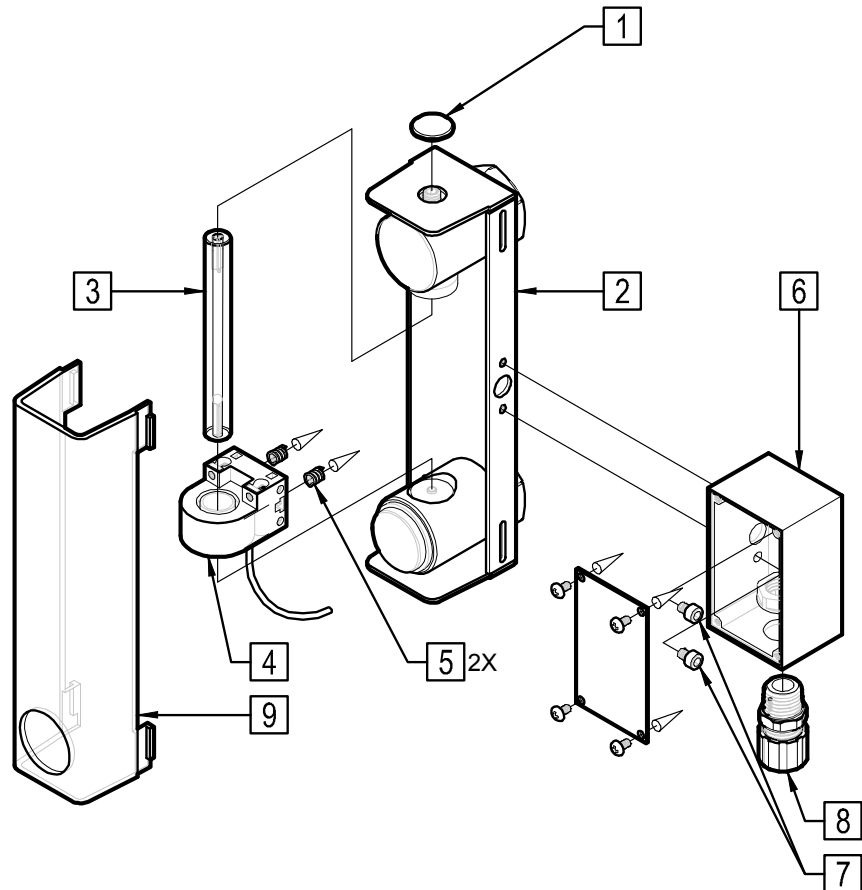

7430 SERIES FIBER OPTIC SENSOR

FIBER OPTIC SENSOR:

All 7430 Series flowmeters may be fitted with one fiber optic sensor.

The fiber optic sensor is mounted to the frame with a screw in a slotted screw for adjustability. The sensor uses a pair of fiber optic cables with an emitter and receiver to transmit the light generated by the sensor. The sensor can interface directly to a Programmable Logic Controller (PLC) or when connected to a separate relay can trigger a local or remote alarm.

FIBER OPTIC SENSOR-ELECTRICAL SPECIFICATIONS

SUPPLY VOLTAGE:	10-30V DC
SUPPLY CURRENT:	25mA
OUTPUT:	NPN Sinking, N.O. & N.C. PNP Sourcing, N.O. & N.C.
OUTPUT RATING:	150mA max. Total Load
OUTPUT RESPONSE TIME:	1ms
OFF STATE LEAKAGE CURRENT:	1 MICROAMP @ 30V DC
OUTPUT SATURATION VOLTAGE:	<=1V at 10mA DC >=1.5V at 150mA DC
REPEATABILITY:	0.25ms
HOUSING RATING:	IP67; NEMA 6
OPERATING TEMPERATURE:	-5°F TO +131°F

7430 SERIES ASSEMBLY WITH FIBER OPTIC SENSOR PARTS LIST:

1. Top Frame Plug
2. Frame Assembly
3. Glass Meter Tube Assembly
4. Fiber Optic Housing Screw
5. Fiber Optic Housing
6. Alarm Junction Box
7. Alarm Junction Box Screw
8. Strain Connector
9. Fiber Optic Cable
10. Fiber Optic Adaptor
11. Fiber Optic Sensor
12. Shield

