



FLOW METER LIMITED WARRANTY

Meters are warranted against defects in materials and workmanship to the original user for a period of thirteen (13) months from the date of factory shipment, provided the meter is installed, operated and maintained in accordance with King Instrument Company's instructions and recommendations.

This warranty does not apply if failure is caused or contributed to by any of the following: improper handling, improper storage, abuse, unsuitable application of the product, lack of reasonable and necessary maintenance, use exceeding suggested pressure and temperature maximums, improper packaging for return, or repairs made or attempted to be made by anyone other than King Instrument Company, Inc.

KING INSTRUMENT COMPANY, INC. MAKES NO WARRANTY AS TO THE FITNESS OF ITS PRODUCTS FOR SPECIFIC APPLICATIONS.

This warranty is valid for the original end-user only and does not apply to products that have been damaged or modified. This warranty is non-transferrable and is limited to replacement or repair. The liability of King Instrument Company arising out of its supply of the products, or their use, shall not in any case exceed the cost of correcting defects in the products as set forth above.

THIS WARRANTY IS A LIMITED WARRANTY AND SHALL BE IN LIEU OF ANY OTHER WARRANTIES, EXPRESSED OR IMPLIED, INCLUDING BUT NOT LIMITED TO ANY IMPLIED WARRANTY OR MERCHANTABILITY OR FITNESS FOR A PARTICULAR PURPOSE. THERE ARE NO OTHER WARRANTIES WHICH EXIST BEYOND THE DESCRIPTION OR FACE HEREOF.

IN NO EVENT SHALL KING INSTRUMENT COMPANY BE LIABLE FOR LOSS OF PROFITS, INDIRECT, CONSEQUENTIAL OR INCIDENTAL DAMAGES.

Products should be returned, prepaid, to King Instrument Company, Inc. with proof of purchase. Call factory for Return Merchandise Authorization (RMA) number and return instructions.

THIS IS IMPORTANT INFORMATION. READ IT CAREFULLY BEFORE BEGINNING WORK.

- 1) Inspect meter for damage that may have occurred during shipping. Report any damage to the container to the freight carrier immediately.
- 2) Make sure your pressure, temperature, fluid and other requirements are compatible with the meter.
- 3) Select a suitable location for installation to prevent excess stress on the meter which may result from:
 - a) Misaligned pipe.
 - b) The weight of related plumbing.
 - c) "Water Hammer" which is most likely to occur when flow is suddenly stopped as with quick closing solenoid operated valves. (If necessary, a surge chamber should be installed. This will also be useful in pressure start-up situations.)
 - d) Thermal expansion of liquid in a stagnated or valve isolated system.
 - e) Instantaneous pressurization which will stress the meter and could result in tube failure.
- 4) Handle the meter carefully during installation.

NOTE: In closed thermal transfer or cooling systems, install the meter in the cool side of the line to minimize meter expansion and contraction and possible fluid leaks at the threaded connections.

- a) Use an appropriate amount of teflon tape on external pipe threads before making connections. Do not use paste or stick type thread sealing products.

- b) Extreme caution should be exercised when using PVC solvent cement around Acrylic. Acrylic cannot tolerate PVC solvent cement and/or pipe dope. The fumes can cause crazing or cracking of the acrylic. If flowmeters are to be installed in a glued pipe configuration, install flowmeter after all glued fittings are dried and lines are purged of all fumes.
- c) Over tightening of plastic connections may result in fitting damage.
- 5) Install the meter vertically with the inlet port at the bottom.
- 6) End fitting must be held secure when installing pipe. Failure to do so can cause damage to the meter itself.

Revised note

- 7) Meters with plastic fittings must be installed so that fittings are not made to support any part of the associated plumbing. In addition, meter frame should be fastened to bulkhead, panel or column.
- 8) Meters used in gas service should have suitable valves plumbed in at the inlet and outlet of the meter. These valves should be no more than 1-1/2 pipe diameters from the meter ports. The valve at the outlet should be used to create back pressure as required to prevent float bounce. It should be set initially and then left alone. The inlet valve should be used for throttling purposes. Depending on the installation, valves may not be essential, but they are most useful in many installations. Remember: To get a correct reading of flow in gas service, it is necessary to know the pressure right at the outlet of the meter (before the valve).
- 9) Pressure and temperature maximums must never be exceeded.

Maximum Non-Shock Pressure and Temperature		
Fluid	Temperature	Pressure
Liquid	130° F	150 psig
Gas	100° F	125 psig
Ambient Temp. 33° F -125° F		

CAUTION

- 7520 / 7530 meters are not oxygen cleaned. Use with incompatible fluids may cause o-rings to swell and break.
- O-rings should be replaced if meter is disassembled after it has been in service.
- Extra caution must be exercised when meters are used in high pressure gas cylinder applications. Pressure regulators should be installed at the cylinder and at the inlet of the meter.
- Serious property damage and great personal injury could occur as the result of a meter misused or used in an unsuitable application.

DO NOT USE AN INLET OR OUTLET VALVE AS A SHUT-OFF VALVE.

Valves are designed to be used to control flow only. Do not use an inlet or outlet valve as a way to shut-off a system. This can cause damage to the meter as well as the system it is installed in. In an outlet valve configuration, too much pressure can build up in the meter and cause a failure in the tube if used as a shut-off valve.

CLEANING

Carefully remove the flowmeter from piping system. Remove the threaded outlet fitting and withdraw the float from the top. All necessary instrument components are now fully accessible for cleaning with a bottle brush and appropriate mild soap solution*. Before the meter is reassembled, inspect all parts for damage. O-rings should be replaced during meter maintenance and cleaning.

To reassemble, carefully guide the float back into the tube. When installing float/guide assembly make certain that the end of the guide fully engages the inlet and/or outlet float stop. Reinstall and tighten fittings in appropriate ports. Reinstall the instrument into the plumbing system after removing the old teflon tape (with a wire brush) and replacing with fresh teflon tape.

*Do not use cleaning agents that will damage float, tube or o-rings.

Meters should be cleaned with a mild soap solution. This will be an effective cleaner of rust stains. Caution must be used so that materials of construction are not damaged by cleaning solutions. Hard water deposits can be removed with 5% acetic acid solution (vinegar).

REPAIR

7520 / 7530 meters that require repair should be sent to the factory. Please call for a Return Merchandise Authorization (RMA) number and return instructions.

WARNING:

Pressure and temperature ratings are based on a study of the engineering data for particular materials used in construction and on the design of individual models. This information is supplemented by destructive test results. Meters with stainless enclosures must never be operated without shields securely in place. Meters exposed to difficult environments such as those created by certain chemicals, excessive vibration or other stress inducing factors could fail at or below the suggested maximums. Never operate meters above pressure and temperature maximums. It is strongly recommended that all meter installations utilize an appropriate pressure relief valve and/or rupture disc. The pressure settings and locations of these devices should be such that meters cannot be over pressurized. Meter failure could result in damage to equipment and serious personal injury. Always use suitable safety gear, including OSHA approved eye protection when working around meters in service. We are happy to pass along chemical compatibility information that has been published by the manufacturer's of raw materials used in our products; however, this information should not be construed as a recommendation made by King Instrument Company, Inc. for a specific application.

FLOAT TYPES AND ORIENTATIONS

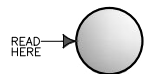

BL FLOAT

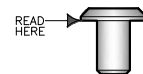

GV FLOAT

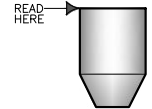

SL FLOAT

7520-7530 Series

INSTALLATION INSTRUCTIONS

7520 SERIES ASSEMBLY 2C BLOCK - WITHOUT GUIDE ROD PARTS LIST:

1. Acrylic Meter Block
2. Back Plate
3. End Fitting O-Ring
4. Outlet End Fitting
5. Inlet End Fitting
6. End Fitting Nut
7. Float
8. Top Plug O-Ring
9. Top Plug

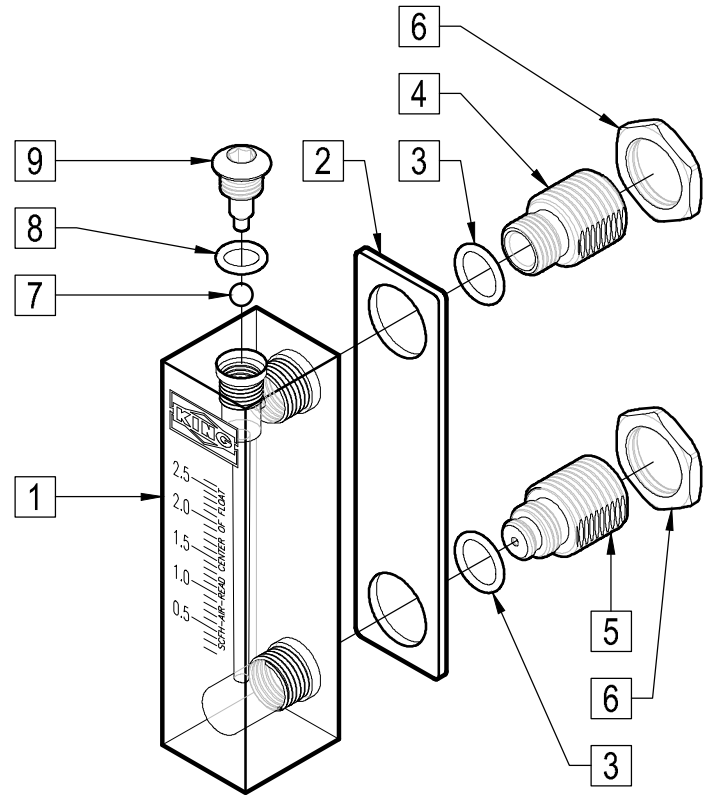

7530 SERIES ASSEMBLY - WITH INLET VALVE 2C BLOCK - WITHOUT GUIDE ROD PARTS LIST:

1. Acrylic Meter Block
2. Back Plate
3. End Fitting O-Ring
4. Outlet End Fitting
5. Inlet End Fitting
6. End Fitting Nut
7. Float
8. Top Plug O-Ring
9. Top Plug
10. Valve O-Ring
11. Valve Assembly

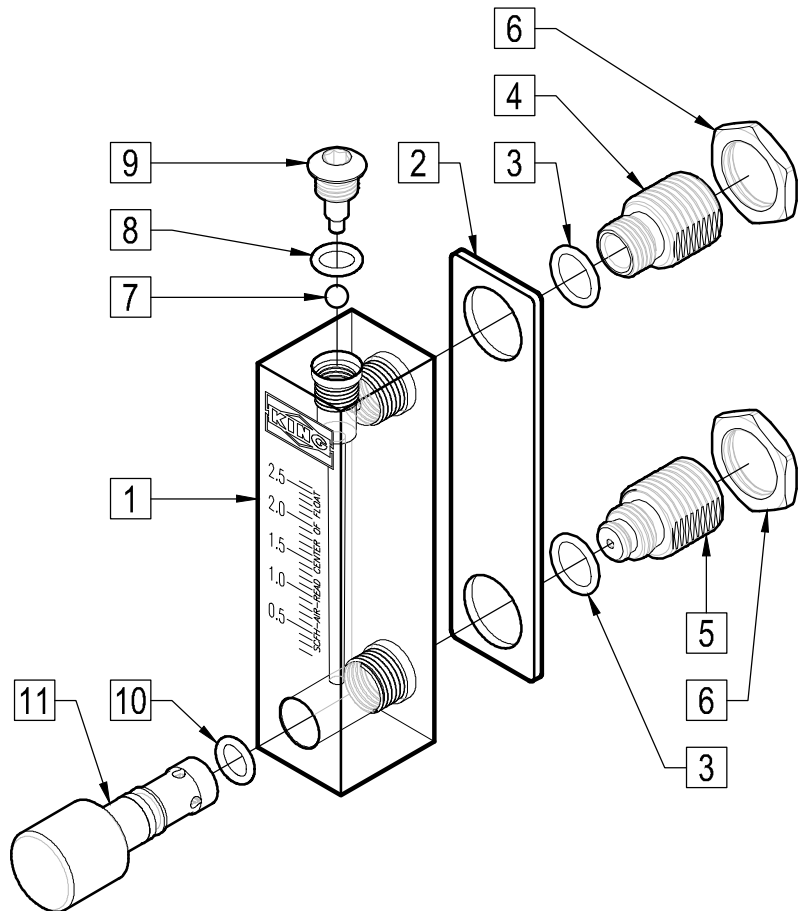

7520-7530 Series

INSTALLATION INSTRUCTIONS

7520 SERIES ASSEMBLY 2C BLOCK - WITH GUIDE ROD PARTS LIST:

1. Acrylic Meter Block
2. Back Plate
3. End Fitting O-Ring
4. Outlet End Fitting
5. Inlet End Fitting
6. End Fitting Nut
7. Top Plug / Guide Rod Assembly
8. Float

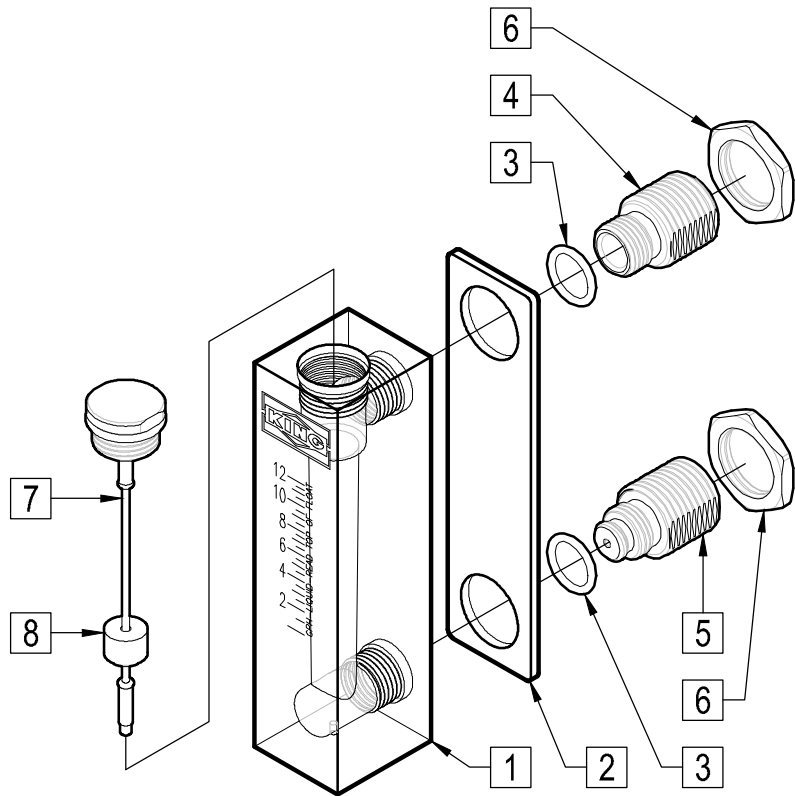

7530 SERIES ASSEMBLY - WITH INLET VALVE 2C BLOCK - WITH GUIDE ROD PARTS LIST:

1. Acrylic Meter Block
2. Back Plate
3. End Fitting O-Ring
4. Outlet End Fitting
5. Inlet End Fitting
6. End Fitting Nut
7. Top Plug / Guide Rod Assembly
8. Float
9. Valve O-Ring
10. Valve Assembly

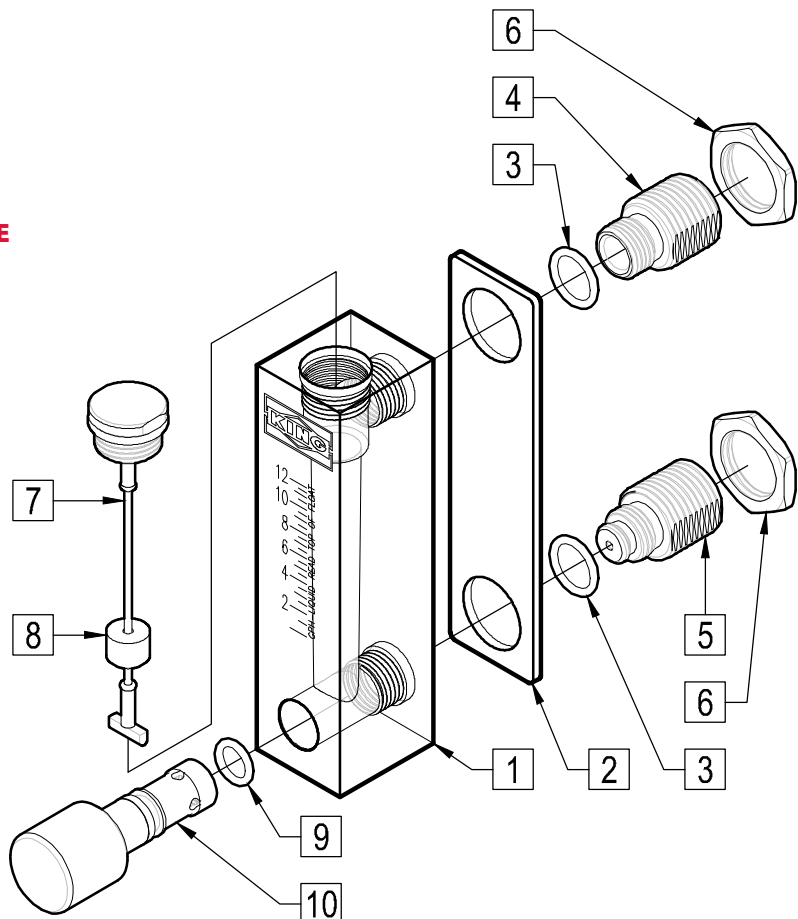

7520-7530 Series

INSTALLATION INSTRUCTIONS

7520 SERIES ASSEMBLY 3C, 5C, 6C, 7C BLOCK PARTS LIST:

1. Acrylic Meter Block
2. End Fitting O-Ring
3. Outlet End Fitting
4. Inlet End Fitting
5. Mounting Stud Assembly
6. Top Plug / Guide Rod
7. Float

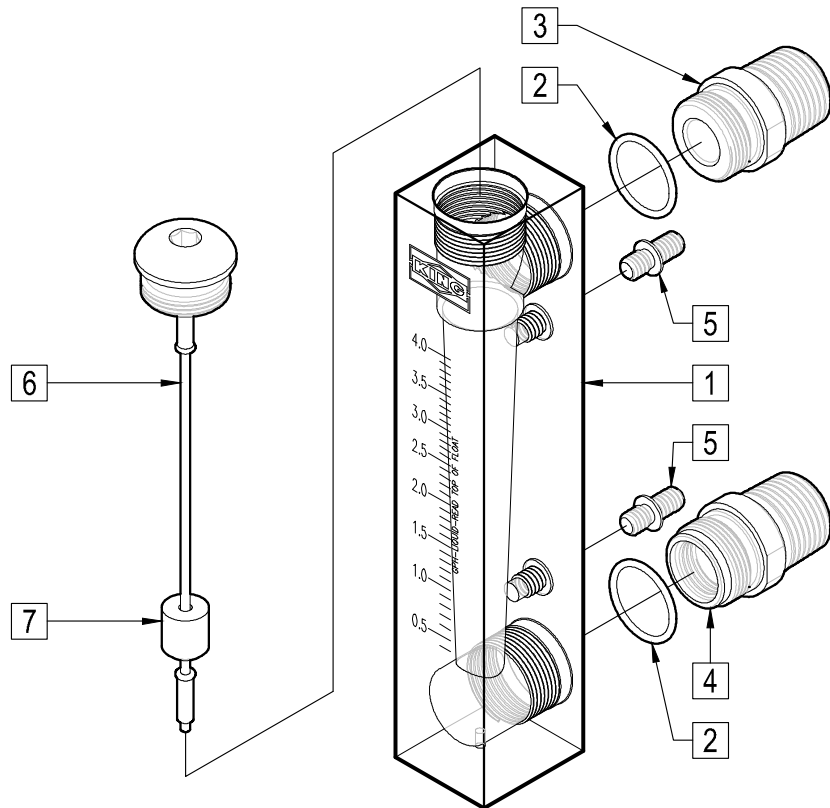

7530 SERIES ASSEMBLY - WITH INLET VALVE 3C, 5C, 6C, 7C BLOCK PARTS LIST:

1. Acrylic Meter Block
2. End Fitting O-Ring
3. Outlet End Fitting
4. Inlet End Fitting
5. Mounting Stud Assembly
6. Top Plug / Guide Rod Assembly
7. Float
8. Valve Spacer (3C and 5C in Brass and Stainless Steel only)
9. Valve O-Ring
10. Valve Assembly

