

FLOW METER LIMITED WARRANTY

Meters are warranted against defects in materials and workmanship to the original user for a period of thirteen (13) months from the date of factory shipment, provided the meter is installed, operated and maintained in accordance with King Instrument Company's instructions and recommendations.

This warranty does not apply if failure is caused or contributed to by any of the following: improper handling, improper storage, abuse, unsuitable application of the product, lack of reasonable and necessary maintenance, use exceeding suggested pressure and temperature maximums, improper packaging for return, or repairs made or attempted to be made by anyone other than King Instrument Company, Inc.

KING INSTRUMENT COMPANY, INC. MAKES NO WARRANTY AS TO THE FITNESS OF ITS PRODUCTS FOR SPECIFIC APPLICATIONS.

This warranty is valid for the original end-user only and does not apply to products that have been damaged or modified. This warranty is non-transferrable and is limited to replacement or repair. The liability of King Instrument Company arising out of its supply of the products, or their use, shall not in any case exceed the cost of correcting defects in the products as set forth above.

THIS WARRANTY IS A LIMITED WARRANTY AND SHALL BE IN LIEU OF ANY OTHER WARRANTIES, EXPRESSED OR IMPLIED, INCLUDING BUT NOT LIMITED TO ANY IMPLIED WARRANTY OR MERCHANTABILITY OR FITNESS FOR A PARTICULAR PURPOSE. THERE ARE NO OTHER WARRANTIES WHICH EXIST BEYOND THE DESCRIPTION OR FACE HEREOF.

IN NO EVENT SHALL KING INSTRUMENT COMPANY BE LIABLE FOR LOSS OF PROFITS, INDIRECT, CONSEQUENTIAL OR INCIDENTAL DAMAGES.

Products should be returned, prepaid, to King Instrument Company, Inc. with proof of purchase. Call factory for Return Merchandise Authorization (RMA) number and return instructions.

THIS IS IMPORTANT INFORMATION. READ IT CAREFULLY BEFORE BEGINNING WORK.

- 1) Inspect meter for damage that may have occurred during shipping. Report any damage to the container to the freight carrier immediately.
- 2) Make sure your pressure, temperature, fluid and other requirements are compatible with the meter and components (including o-rings).
- 3) Select a suitable location for installation to prevent excess stress on the meter which may result from:
 - a) Misaligned pipe.
 - b) The weight of related plumbing.
 - c) "Water Hammer" which is most likely to occur when flow is suddenly stopped as with quick closing solenoid operated valves. (If necessary, a surge chamber should be installed. This will also be useful in pressure start-up situations.)
 - d) Thermal expansion of liquid in a stagnated or valve isolated system.
 - e) Instantaneous pressurization which will stress the meter and could result in tube failure.
- 4) Handle the meter carefully during installation.
 - a) Use an appropriate amount of teflon tape on external pipe threads before making connections. Do not use paste or stick type thread sealing products.
 - b) Over tightening of plastic connections may result in fitting damage.
- 5) Install the meter vertically with the inlet port at the bottom.
- 6) Meters with stainless steel fittings will support several feet of pipe as long as significant vibration or stress resulting from misaligned pipe are not factors.
- 7) Meters with plastic fittings must be installed so that fittings are not made to support any part of the associated plumbing. In addition, meter frame should be fastened to bulkhead, panel or column.
- 8) Meters used in gas service should have suitable valves plumbed in at the inlet and outlet of the meter. These valves should be no more than 1-1/2 pipe diameters from the meter ports. The valve at the outlet should be used to create back pressure as required to prevent float bounce. It should be set initially and then left alone. The inlet valve should be used for throttling purposes. Depending on the installation, valves may not be essential, but they are most useful in many installations. Remember: To get a correct reading of flow in gas service, it is necessary to know the pressure right at the outlet of the meter (before the valve).
- 9) Pressure and temperature maximums must never be exceeded.

NOTE: In closed thermal transfer or cooling systems, install the meter in the cool side of the line to minimize meter expansion and contraction and possible fluid leaks at the threaded connections.

Maximum Non-Shock Pressure and Temperature		
Fitting	Temperature	Pressure
316LSS	200°F	300 psig (31W-47W)
		250 psig (51W-67W)
		75 psig (81W-95W)
PVDF	200°F	150 psig (31W-67W) 75 psig (81W-95W)
Ambient Temp. 33° F -125° F		

CAUTION

- Silver Series meters have o-ring seals. Use with incompatible fluids may cause o-rings to swell which may cause glass tube to fail.
- Serious property damage and great personal injury could occur as the result of a meter misused or used in an unsuitable application.

CLEANING

To minimize downtime, Silver Series metering tubes are designed to be removed without uninstalling the flowmeter from the piping system. Meter should be drained prior to maintenance.

Remove the shield from the frame by loosening the 4 shield screws with a 3/16" hex wrench. Loosen the scale plate screws and remove the scale plate. Loosen the tube retainer screws and pull the tube retainer forward. Rotate the glass tube to loosen the o-ring seal. Carefully push the glass tube up until its bottom clears the inlet fitting. Angle the bottom of the glass tube down and away from the frame. Use caution. Pulling the glass tube at an extreme angle, or by excessive force will cause the tube to break. Do not allow the float to fall. Float damage may result in meter inaccuracy.

Inspect all parts for damage prior to re-assembly. Replacement of o-rings during meter maintenance is recommended. O-rings should be generously lubricated using a silicone based o-ring lubricant. Insert the float and float stops into the glass tube. Make sure the orientation of the float is correct prior to installing. Carefully slide glass tube assembly onto top fitting at a slight angle and align with bottom fitting. Secure the tube by pushing the tube retainer between the glass tube and the upper fitting and tighten the screws. Replace the scale plate making sure the reference line on the scale is aligned with the reference line on the glass tube. Re-install the front shield.

*Do not use cleaning agents that will damage float, tube or o-rings.

Meters should be cleaned with a mild soap solution. This will be an effective cleaner of rust stains. Caution must be used so that materials of construction are not damaged by cleaning solutions. Hard water deposits can be removed with 5% acetic acid solution (vinegar).

REPAIR

Silver Series meters that require repair should be sent to the factory. Please call for a Return Merchandise Authorization (RMA) number and return instructions

WARNING:

Pressure and temperature ratings are based on a study of the engineering data for particular materials used in construction and on the design of individual models. This information is supplemented by destructive test results. Meters with stainless enclosures must never be operated without shields securely in place. Meters exposed to difficult environments such as those created by certain chemicals, excessive vibration or other stress inducing factors could fail at or below the suggested maximums. Never operate meters above pressure and temperature maximums. It is strongly recommended that all meter installations utilize an appropriate pressure relief valve and/or rupture disc. The pressure settings and locations of these devices should be such that meters cannot be over pressurized. Meter failure could result in damage to equipment and serious personal injury. Always use suitable safety gear, including OSHA approved eye protection when working around meters in service. We are happy to pass along chemical compatibility information that has been published by the manufacturer's of raw materials used in our products; however, this information should not be construed as a recommendation made by King Instrument Company, Inc. for a specific application.

9000 Silver Series

INSTALLATION INSTRUCTIONS

SILVER SERIES ASSEMBLY PARTS LIST:

- | | | | |
|--------------------------------------|----------------------|-------------------------------|------------------------|
| 1. End Fitting Retainer Screw | 6. Case | 12. Tube Retainer | 18. Scale Plate |
| 2. End Fitting Retainer Split Washer | 7. Outlet Float Stop | 13. Inlet End Fitting | 19. Scale Plate Screw |
| 3. End Fitting Retainer | 8. Float | 14. Tube Retainer Screw | 20. Shield |
| 4. Outlet End Fitting | 9. Glass Meter Tube | 15. Upper Scale Plate Bracket | 21. Shield Flat Washer |
| 5. End Fitting O-Ring | 10. Inlet Float Stop | 16. Lower Scale Plate Bracket | 22. Shield Screw |
| | 11. Glass Tube Saver | 17. Scale Plate Bracket Screw | |

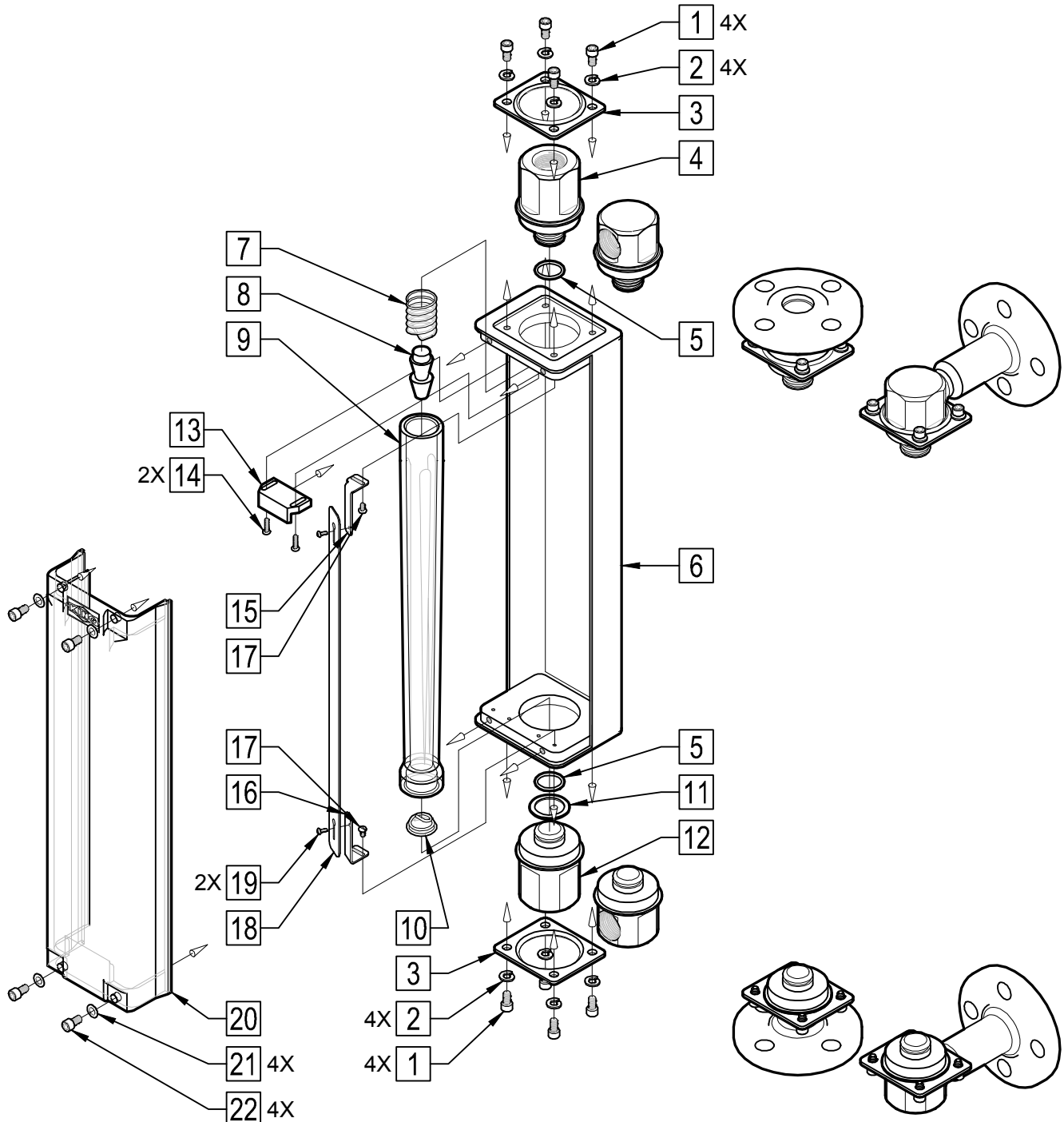

LATCHING REED SWITCH

LATCHING REED SWITCH

All Silver Series flowmeters may be fitted with one or two latching reed switches.

The switch assembly is mounted on the scale plate. The switch can be positioned to trip at any point on the scale.

The switch is a reed type and uses a biasing magnet to give it the latching feature. The float contains hermetically sealed magnet(s), so when the float comes in proximity to the switch it closes and remains closed (latched) when the float moves below the switch it resets itself. Contact King Instrument Company for multiple switch options.

LATCHING REED SWITCH-ELECTRICAL SPECIFICATIONS

TYPE:	SPST
POWER:	4W Max.
SWITCHING VOLTAGE:	30V DC Max.
BREAKDOWN VOLTAGE:	200V DC Min.
SWITCHING CURRENT:	0.2A Max.
CARRY CURRENT:	1.4A Max.
INITIAL CONTACT RESISTANCE:	0.020 Ohm Max. @ 50% magnetic overdrive

SWITCH ISOLATOR OPTION:

Latching reed switches can be used as stand alone devices, or may be connected to a switch isolator for intrinsically safe applications. The purpose of the switch isolator is to supply electrical signals between safe and hazardous areas in either direction while limiting the amount of energy that can be transferred even under fault conditions. Switch isolators are available with 220VAC, 110VAC or 24VDC supply voltage requirements, contain single pole double throw (SPDT) relays, and are DIN rail mountable. See switch isolator specifications for electrical connections and further details.

FLOAT TYPES AND ORIENTATIONS

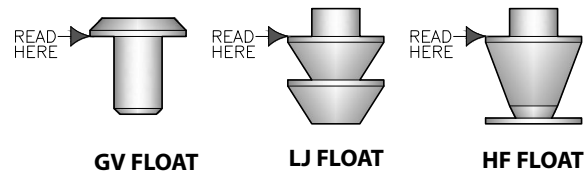
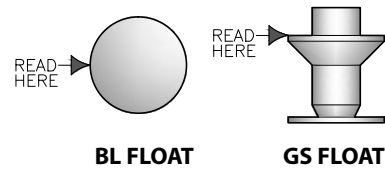

CONNECTIONS - INTRINSICALLY SAFE WIRING

Single Switch		Dual Switch	
1 (+)	High Switch	1(+)	2(-)
2 (-)	Low Switch	4(+)	5(-)

9000 Silver Series

INSTALLATION INSTRUCTIONS

SILVER SERIES ASSEMBLY WITH ALARM PARTS LIST:

- | | | |
|--------------------------------|-----------------------------------|-----------------------------|
| 1. Meter Assembly | 6. Ground Lock Washer | 11. Alarm Scale Plate Screw |
| 2. Alarm Switch Assembly | 7. Alarm Switch Housing Wing Nut | 12. Shield |
| 3. Alarm Switch Assembly Screw | 8. Alarm Switch Housing | 13. Shield Flat Washer |
| 4. Alarm Connector Plug | 9. Alarm Switch Housing Set Screw | 14. Shield Screw |
| 5. Ground Nut | 10. Alarm Scale Plate | |

